

# Sound Anchors Motorized Fixed Start ADMID Instructions



Sound Anchors  
2835 Kirby Cir NE Unit 110  
Palm Bay, FL 32905  
321-724-1237  
[Office@Soundanchors.com](mailto:Office@Soundanchors.com) [www.soundanchors.com](http://www.soundanchors.com)



## Sound Anchors Motorized Fixed Start ADMID Stands

Thank you for choosing Sound Anchors stands for your studio. Our stands can make a significant difference in studio recordings because they help ensure accurate and precise sound reproduction. Also, by providing a stable and isolated platform for the speakers, our stands can help reduce unwanted resonance and distortion, improve imaging and bass response, and create a cleaner, clearer sound. Please read all instructions before assembling the stands.

### HARDWARE LIST



#### Hardware Inventory:

- 4 ea. 3/8-16 Jam Nuts
- 4 ea. 3/8 Flat Washers
- 4 ea. 3/8-16 spikes
- 4 ea. Black & Blue Dots (not pictured)
- 4 ea. 3/8-16 x 3/4 Low Head Socket Head Cap Screws
- 4 ea. 7/16-14 x 3/4 Hex Head Cap Screws (gold)
- 4 ea. 7/16-14 x 1 Flat Head Cap Screws (installed)
- 4 ea. 5/16-18 x 3/4 Socket Head Cap Screws
- 8 ea. M6-1 x 20 Button Head Cap Screw (installed)
- 8 ea. M6 flat washers (installed)
- 8 ea. M6-1 x 20 Socket Head Cap Screws
- 8 ea. M6 Flat Washers (not pictured)
- 1/4" Hex Wrench
- 3/8" Hex Wrench
- 3/16" Hex Wrench

## Sound Anchors Motorized F ADMID Parts List

- 1) 2 ea. Moto ADMID Feet
- 2) 1 ea. Lower Cross Member
- 3) 1 ea. Upper Cross Member
- 4) 2 ea. Speaker Support Bars
- 5) 2 ea. Motor Lift Assembly



Parts 1 - 4 shown are Sound Anchors manufactured parts for the Motorized Fixed ADMID stand. Part 5 consists of Manufactured parts, along with “upright risers” and “Motor Cradle” but also consists of an electrical part from Linak. There are also other Linak components.

## Assembly

(Do not tighten down any screws until the stands are fully assembled)

1. Assemble the Spike, Jam nut, and Washer by threading the nut onto the spike until it is set at the end of the threads of the spike. Lay the washer on top of the nut and screw the spikes onto the feet of the stand. Make sure they are hand tight. When the stand is fully assembled, adjustments can be made to the spikes to level the stand.

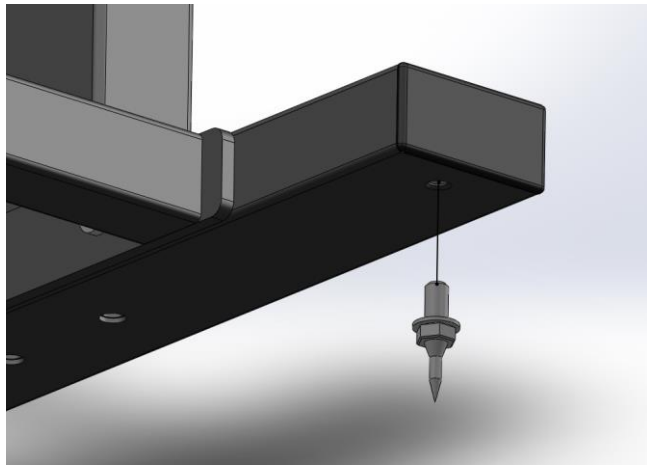

2. Fasten the 2 Feet to the lower cross piece with the 3/8-16 x 3/4 Low Head Socket Cap Screws.

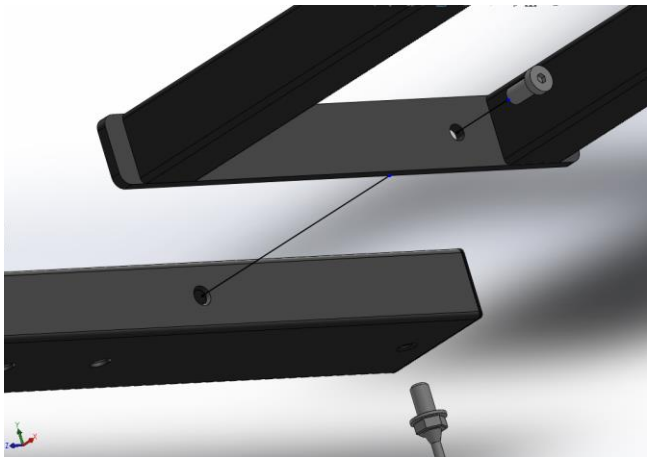

3. Fasten the upright risers to the lower cross assembly by fitting the risers into the pocketed hole in the top of each foot. Ensure the riser is seated all the way down into the foot. Fasten them together with the 7/16-14 x 3/4 Hex Head Screw (Gold).

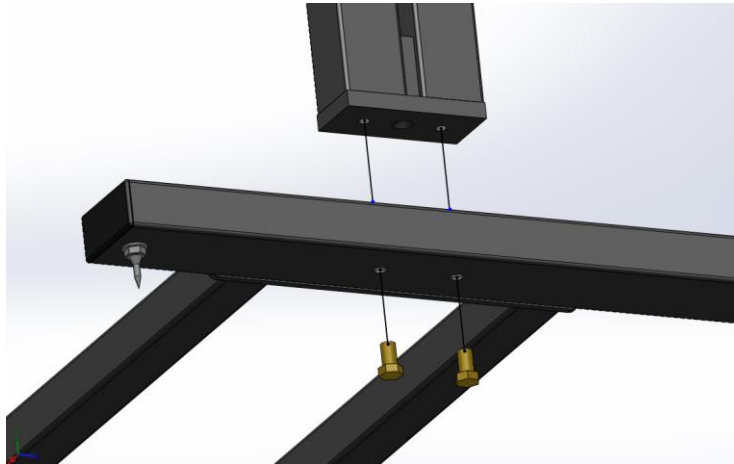

4. Attach the upper cross piece to the Top of both motors using the M6 socket head cap screws with M6 washers. There may be a need to pull the uprights together or apart from the center to ensure the crosspiece fits on the stand.

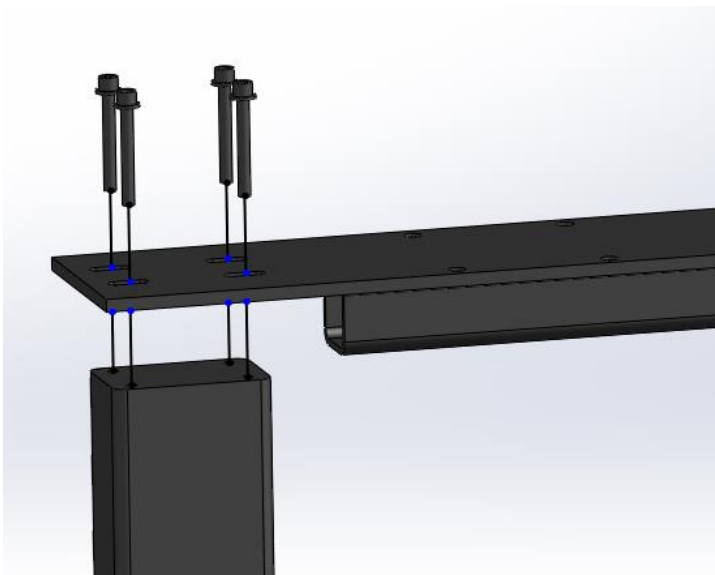

5. Attach the support bars to the upper cross piece by fastening the 5/16-18 x 3/4 Socket Head Cap Screws through the bottom of the crosspiece plates. The screws will thread into the support bar from below.

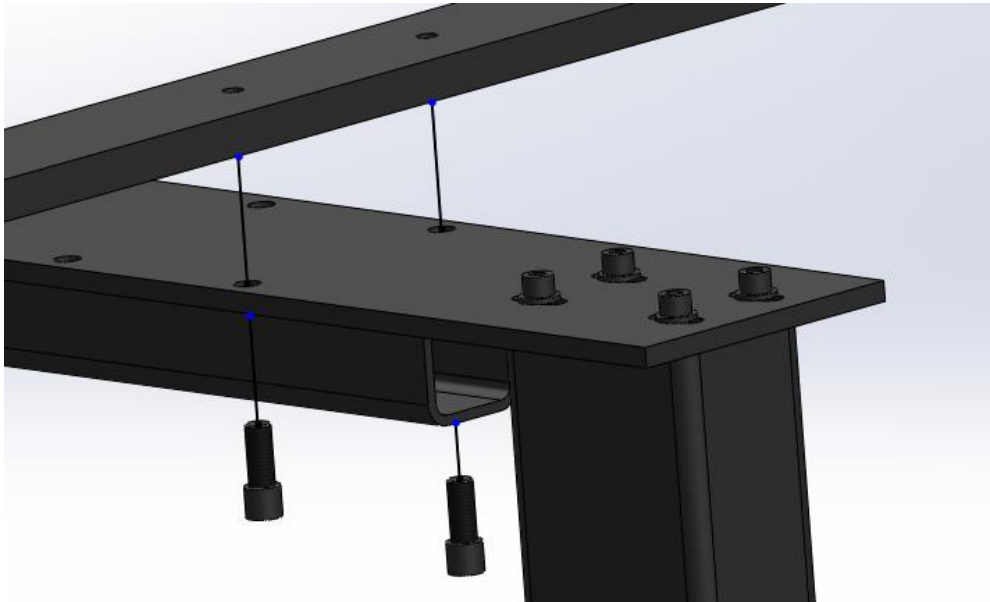

6. Lastly, tighten down any bolts left loose for fitment. Leveling should be done at this point. Add the Black & Blue dots to each end of each support bar (blue side down, black side up – speaker should be placed on black side of Sorbothane pad) and place your speaker on top. The Speaker should appear to be centered on the stand when you look at it from the front or the side. Keeping the center of gravity within the footprint of the stand will maximize stability and performance.

## **Important Black & Blue Dot Guidelines**

Sound Anchors' Black & Blue Dots are made of urethane coated Sorbothane. Sorbothane is unique in that it absorbs motion in all directions making it an ideal isolation material between speakers and stands. Black & Blue Dots do not have adhesive on them. The blue side should be placed on the stand and the black side should be placed under the speaker. However, under the weight of the speaker and over time they will compress and become gummy and possibly discolor or mar the finish on the bottom of the speaker. Under certain conditions they may also adhere to the bottom of your speakers, causing difficulty in removing or repositioning the speaker. The urethane coating has been added to help alleviate this issue.

Care should be used when removing speakers from the stands as to avoid damaging the bottom of the speaker. It is recommended that a thin blade (i.e. putty knife) be slid in between the speaker and the platform to break the adhesion and dislodge the Black & Blue Dot. Black & Blue dots should not be used on speakers with a lacquer finish. These surfaces are highly susceptible to marring from use of the Black & Blue dots.

## **MOTOF ADMID Stand**

The Motorized ADMID stand is one of our newest designs. It takes the adjustability of our ADMID stand and combines it with the ease and convenience of the Motorized stands. There is a bit more assembly required, but if you have a center channel speaker that needs to be moved out of the way in some applications, or speakers that need to be used in multiple locations, this is the stand for you!

If you have any questions about the stands, or any feedback, please contact Sound Anchors at (321) 724-1237. We can also be reached by email at [info@soundanchors.com](mailto:info@soundanchors.com).