

SET UP INSTRUCTIONS FOR SOUND ANCHOR Epicon 6 STANDS

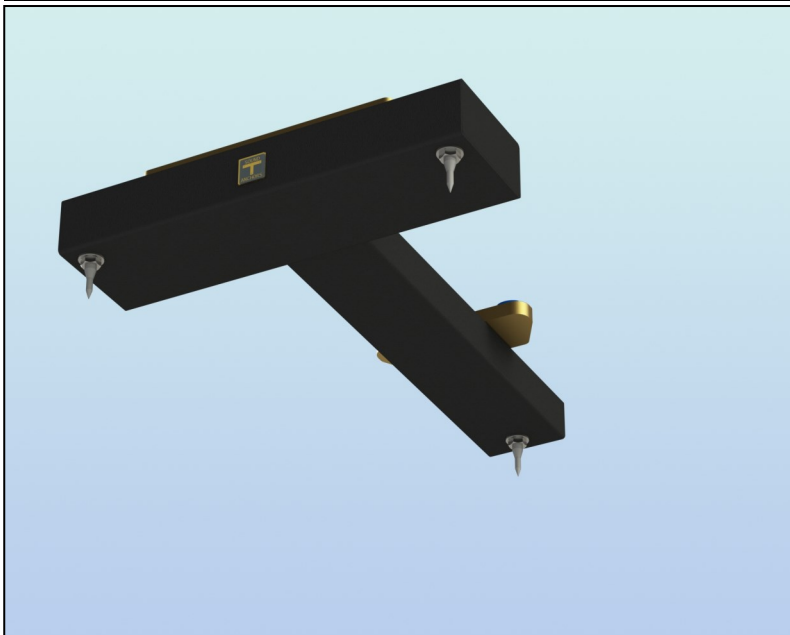
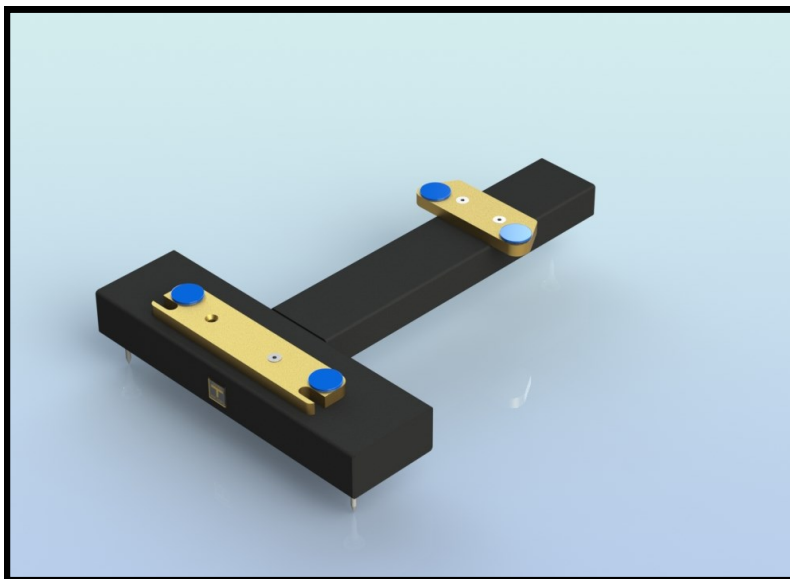

**SOUND ANCHORS INC.
2835 KIRBY Circle. #110
PALM BAY, FL. 32905 USA
PHONE (321) 724 1237
e-mail info@soundanchors.com
www.soundanchors.com**

Thank you for purchasing Sound Anchor stands for your Dali Epicon 6 Speakers. We designed your stands to optimize the driver position in relation to your listening position and to lessen the effect that your room will have on the sound coming from your speakers. This means that your speakers will be able to reproduce both music and movie soundtracks more accurately and with more life than is possible with your speakers on the floor

Speaker placement is the single most important factor when it comes to system setup. There is no magic or scientific formula that will ensure best position so please take the time to experiment with speaker placement in your room before you place your speakers on the stands. The speakers will be considerably more difficult to move once they are up on the stands.

INVENTORY

- 1. 2 ea. Stand Weldments**
- 2. 6 ea. Short Spikes**
- 3. 2 ea. Medium Spikes**
- 4. 6 ea. 3/8-16 Jam Nuts**
- 5. 6 ea. 3/8" SAE Flatwashers**
- 6. 4 ea. Special M8 Studs**
- 7. 8 ea. Bluedots**

SETUP

1. Before you place your speakers up on the stands mark your desired speaker locations on your floor with masking tape.

2. Install the spikes washers and jam nuts into the threaded inserts in the bottom of the stand.

NOTE: There are two options when installing spikes in Sound Anchor Epicon 6 Stands. The first is the three equal spike method. This arrangement tilts your speakers back slightly. The other setup uses 2 short spikes in the front and 1 medium spike in the rear insert. The second arrangement sets the speaker up level. The tall stands use the same spikes on all corners

SHORT SPIKES ONLY

The spike arrangement is your choice. In general if you have a smallish room or are going to be sitting close (<8 feet) you should start out with the two short one medium spike arrangement and set up your speaker level. If you have a normal to large room you may want to experiment with tilting the speaker back slightly. This usually* gives a bit larger soundstage and

makes the sound become less tied to the speakers. The treble will usually be softened slightly when you tilt the speaker

3. Place your speaker stands where you have previously marked your speaker location using masking tape. Remove the masking tape.
4. Install two special M10 set screws into the two front spike inserts on the bottom of the speakers See fig. 1 They should be screwed in so that the end of the screw sticks out approximately 5mm .
5. Place 4 bluedots on the stand as shown on fig. 2
6. You may now place your speakers on the stands!! Lift the speakers straight up and lower them so that the 2 studs line up with the 2 alignment slots on the front top cross bars of the stands. See fig. 2
7. Line up the speaker with the stand so that the speaker is centered side to side and the front of the edge of the speaker lines up with the front surface of the stand.
8. Adjust tilt so that both stands are the same then tighten the Jam Nuts.

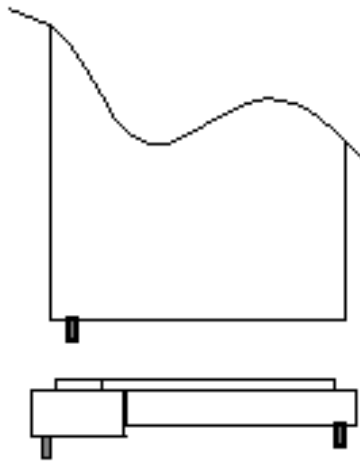

Fig. 1

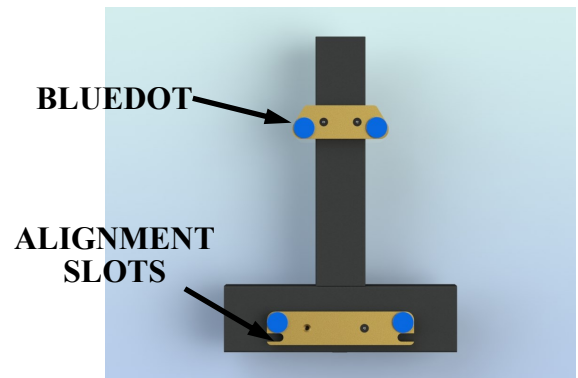

Fig. 2

9. If you find a need to move your speaker system it is advisable that you take your speakers off of the stands first, relocate the stands then repeat step 2 on

10. Sit back and enjoy your system